

**INDUSTRIAL APPLICATION OF ELECTRON BEAM CURING IN THE
FIELD OF COATINGS.**

29th – 31st January 2003

B. Laurell, E. Föll
Electron Crosslinking AB
Pilefeltsgatan 81
SE-302 50 Halmstad
Sweden

1. INTRODUCTION

There is an ever-increasing demand for solvent-free systems for surfaces coating. During the curing process there should be no emission of harmful substances into the atmosphere or water. In addition, after the curing process is over, there should be no odour emissions from the surface.

These two requirements are already making Electron Beam curing (EB) the focus of ever more attention, not least because this technology has been used for a wide variety of applications in recent years due to the many other benefits it offers.

EB is the abbreviation for a environmentally safe, heat and solvent free technique: **Electron-Beam** curing.

Nevertheless, success is only possible if the user, the chemical supplier and the plant manufacturer collaborate fully - not only during the planning phase but also in the construction of the curing line and later during initial operation.

2. THE ACCELERATOR

The functioning of the electron beam accelerator can best be compared with the cathode ray tube of a TV. Fig. 1.

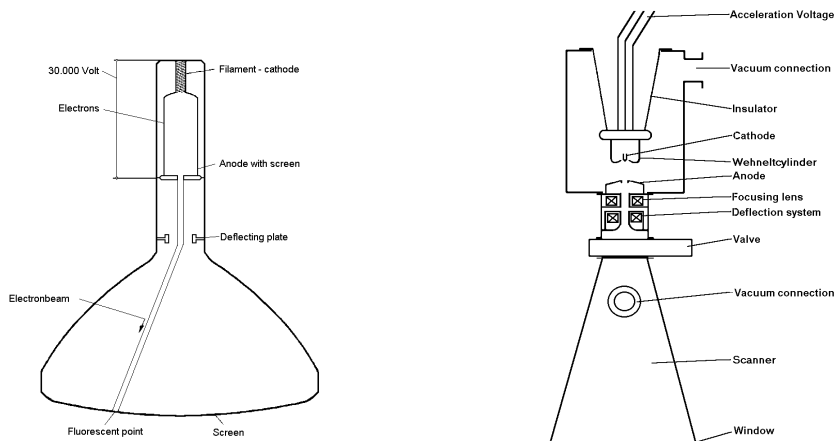

Fig. 1.: Cathode ray tube and Electron Crosslinking electron beam accelerator

A tungsten cathode heated in high vacuum by an electrical current makes free electrons available on its surface. In a TV set the electrons (negatively charged particles) are accelerated by a high negative voltage towards the anode and then deflected to the screen, or to the electron-beam exit window in the electron-beam accelerator. In the accelerator these electrons then emerge from the vacuum through a

thin piece of titanium foil into the air or an inert gas where they can act upon the material.

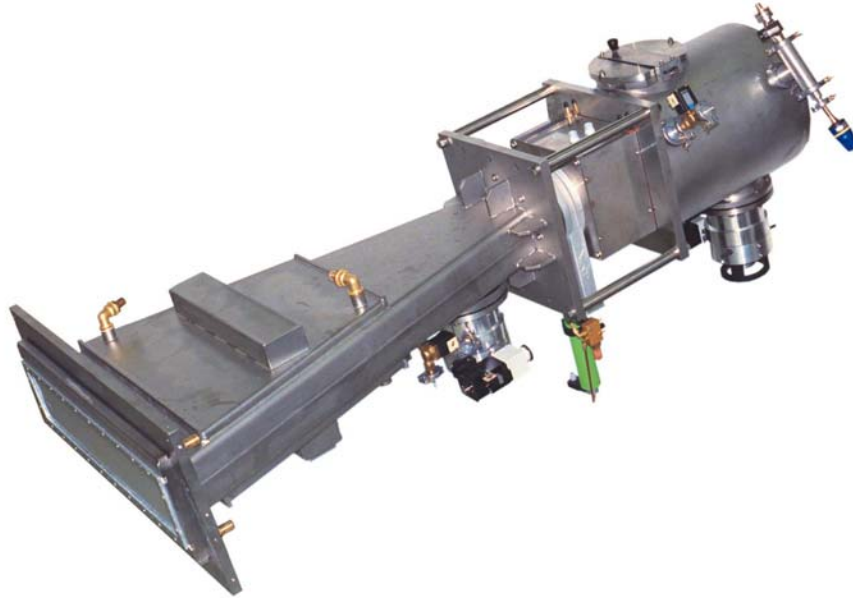

Fig. 2: Picture of Electron Beam Accelerator, 250 kV accelerating voltage and 1,20 m working widths.

3. ENERGY TRANSFER

The transfer of energy from the electron beam into material is specified completely by four parameters:

- Depth of penetration
- Absorbed dose
- Dose uniformity
- Throughput

3.1 Depth of Penetration

Penetrating power of the electron beam is related to the accelerating voltage and the density of the processed material. Higher voltage causes deeper penetration, and denser material reduces the depth of penetration. The Depth Dose Curves (Fig 3) are convenient aids for estimating the penetration depth. These curves shows the penetration for different accelerating voltage to the depth of penetration in a material with mass density equal to that of water, i.e. $\rho = 1 \text{ g/cm}^3$.

Penetration into materials of different density can be estimated by multiplying the penetration depth, found from the normalized curves, by the ratio of the density of water to the density of the material. For example, a 200 kV beam will have a 50 % dose point at 0,246 mm in water and 0,123 mm in a material twice as dense ($\rho = 2 \text{ g/cm}^3$).

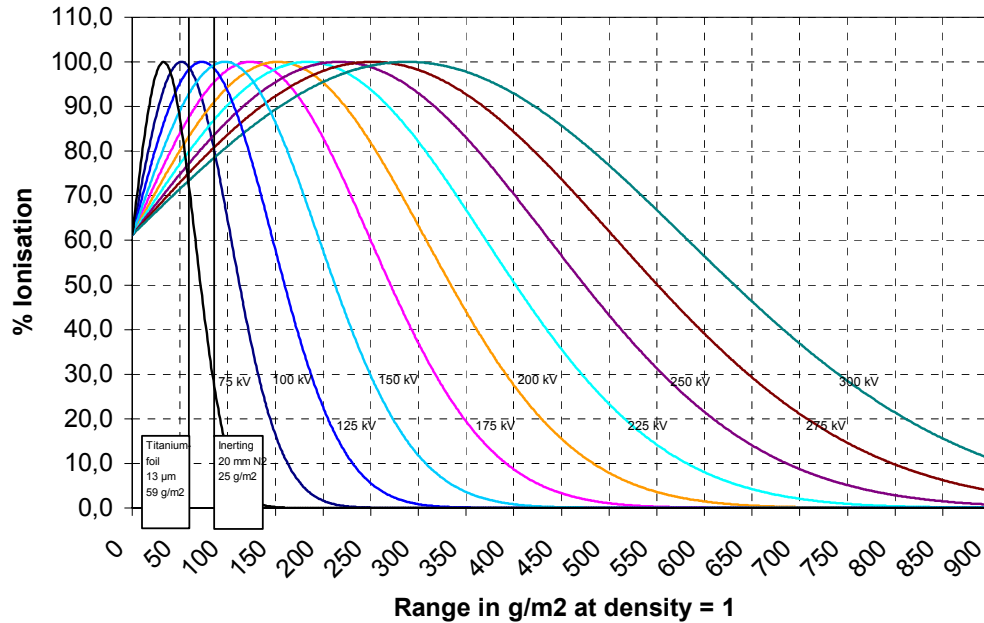

Fig 3.: Range of penetration with different accelerating voltage 13 µm titanium foil and 20 mm of Nitrogen. [22]

At accelerating voltages of 150, 180 and 250 kV respective curing depth of 58, 115 and 250 g/m² are achieved at 80 % ionisation.

Experienced values for industrial accelerating voltages are as follows:

- 80 – 150 kV thin layers in the field of printing inks or silicon-release materials, sterilisation
- 165 – 180 kV furniture foil, pressure-sensitive adhesives
- 180 – 250 kV boards, parquet, panels, lamination
- 250 – 300 kV composite

3.2 Absorbed Dose

Absorbed dose is defined as the amount of energy deposited into a specified mass of material. The unit of absorbed dose is kilogray (kGy), defined as the number of joules (J) of energy deposited into 1 kilogram (kg) of material. An older, but frequently used unit, is megarad (Mrad).

1 kGy = 1 kJ/kg

1 Mrad = 10 kGy = 10 J/g = 2,4 cal/g

- | | |
|--------------------------------|-----------|
| - Heating of water 1 degree | 1 cal/g |
| - Evaporation of water | 540 cal/g |
| - EB-curing of lacquer approx. | 10 cal/g |

At a fixed electron accelerating voltage, the dose is directly proportional to the electron beam current. The dose D [kGy] is proportionate to electron current I [mA] and inverse to web speed v [m/min] as follows:

$$D = k \times \frac{I}{v}$$

with k as equipment factor.

The formula above shows:

- dose and electron current are directly proportional
- if the ratio of electron current and speed are kept constant the dose is constant including start up and shut down of the plant
- the accelerator only uses the quantity of power from the mains supply needed for the used web speed
- quality improvements

Typical values of the dose needed for practical applications are:

- Drying/curing of inks and coatings 15-30 kGy
- Crosslinking of plastic film 25-150 kGy
- Sterilization of medical products 7.5-35 kGy

3.3 Dose Uniformity

Dose uniformity is a direct function of the electron beam uniformity over working width. It is specified as a percentage deviation from the average value, e.g. 20 kGy \pm 10%. In general, Electron Crosslinking Accelerator provides a uniformity better than \pm 5%; many applications can tolerate variations of \pm 10% or more.

3.4 Throughput

Throughput is a measure of the energy deposition rate and relates directly to the amount of material that can be processed within a given time interval. It is measured in kilogray per second, abbreviated kGy/s.

An Electron Crosslinking Accelerator rated at 714 kGy/s can provide a dose of 10 kGy when the web speed is 857 m/min, or 30 kGy at 285 m/min, etc. The processor will automatically adjust the beam intensity as the web speed changes so that the dose remains constant.

4. INDUSTRIAL APPLICATIONS

In all industrial applications the Electron Beam Accelerator itself is the same but the handling system differs:

- material in solid form, as sheet, board, panels etc.
- flexible materials, roll to roll
- laboratory equipment

4.1 Solid materials

In the surface converting of solid materials the EB-technology is successfully used in the following operating fields:

Curing of top lacquer on doors [1], [2]

All-around curing of coated profiles [3], [4]

Curing of the coating on raw boards in the wood industry [5], [6]

Curing of the coating on architectural claddings for outside applications [7], [8]

Curing of the coating on wood-cement boards for outside and inside application [9]

Curing of impregnation and top lacquer on laminated boards

Curing of coated edges and panels in the wood and laminate industry [10]

Curing of coatings on MDF boards (Medium-Density-Fibre-board) [11], [12], [13]

Curing of coatings on three-dimensional parts e.g. rims and pumps housings.

Sterilization

4.1.1 Claddings for outside applications

The coating line receives the produced panels directly from the production line.

The panels, which are made in dimensions from 600 x 150 mm to 3500 x 1250 mm with a thickness of 4 - 30 mm, are cut into final customerized dimensions before they come to the coating line.

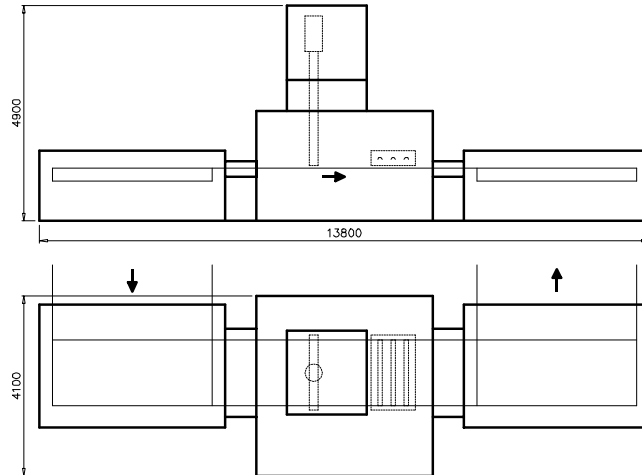

Fig. 4: Electron-beam equipment for boards application (schematically).



Fig. 5: Installation for composite facade panels. (250 kV, 150 mA, 1,2 m)

In order to use the capacity of the line, a group of panels is formed, where the total dimension automatically are optimised as close as possible to the maximum dimension. This group, often called “batch“, is then transported through the complete coating line as one unit.

One batch can contain up to 20 panels, that are coated in one operation.

This way of transportation lead to an optimal use of capacity in combination with a good flexibility for painting custom-unique cut panels.

This technology provides a surface of the facade panels, made for outdoor use, which is extremely resistant to UV-light as well as weather (cold, heat, rain, wind).

In combination with the demands on production speed and the ability to handle the panels immediately after painting, the choice for EB-technology was natural.



Fig. 6: Example of facade claddings with electron cured paint.

The properties of the electron cured claddings can be described as:

- Ageing stability.
- Water and moisture resistant.
- Stands heat / cold variations in combination with moisture / ice.
- Scratch-proof.
- Colour-stable.
- Even gloss level.
- Good resistance to chemicals.

The paint system are built upon an easy-mix system where the colour are mixed together on a general base.

This means that an almost unlimited range of colours, e.g. all colours within the NCS- / RAL- systems.

Furthermore, the properties of the surface is independent of colour.

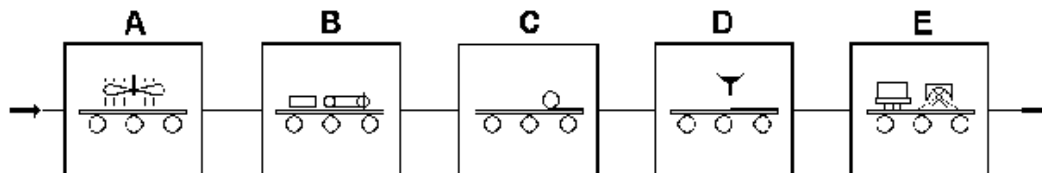

Fig. 8: Principal description of coating line for composite materials.

The main parts of the plant are:

- A. Temperature control.
- B. Sanding equipment, to attain excellent adhesion.
- C. Roller coater for tie coat sealer.
- D. Curtain coater for topcoat.
- E. Electron-beam curing with UV to attain low gloss.

The Advantages of a two step coating are that dust and other small particles are forced down during the first step and creates a smooth, high quality surface.

4.1.2 All-around curing of coated profiles

Coating line for profiled boarder and panels. These boarder are made in several dimensions and designs from 6 - 25 mm thickness and 15 - 200 mm width and a length of 1000 – 5400 mm. Fig. 9.



Fig. 9: Installation for boarder materials. (2 x 180 kV, 30 mA, 300 mm)

To meet the demand of high production capacity (up to 100 m/min) and to be able to pack the boarders directly after the top-coating, the electron-beam curing was the only method that met the requirements.

When using MDF as boarder-material it has to be protected against moisture that stands all transports and storing and to be able to use in many different environments.

The solution in this case was to put coating on all four sides at the same time and to cure it in one operation. This is done with two electron-beam accelerators placed opposite of each other.

The electron-beam cured paint on these borders have the following properties:

- Ageing stability
- Water and moisture resistant
- Scratch-proof.
- Colour-stable
- Graffiti resistant



Fig. 10: Example of all around cured profile.

The application of the coating is done with vacuumat technology close to the accelerators.

4.2 Flexible materials

In the surface converting of flexible materials the EB-technology is successfully used in the following operating fields:

- Vulcanisation or crosslinking of pressure-sensitive adhesives [14]
- Curing of high-gloss coatig of special paper (e.g. photographic paper) [15], [16],[17]
- Curing of release coatings
- Curing of web offset printing inks, finishing varnishes [18], [21]
- Crosslinking of films and foils
- Production of antistatic finish
- Crosslinking of flock adhesives
- Curing of intaglio prints [18], [19], [20]
- Post-crosslinking of binding agents of magnetic materials

Metallizing of paper, e.g. curing of basic lacquer and adhesives for selective or plane transfer metallizing as well as curing of overprints
 Curing of metal coating from roll to roll (coil coating)
 Stabilisation of rubber raw materials by partial vulcanisation
 Crosslinking of laminating adhesives
 Crosslinking of thin insulation of wire and cables
 Colouring of textiles
 Sterilization

4.2.1 Installation for flexible material, roll to roll

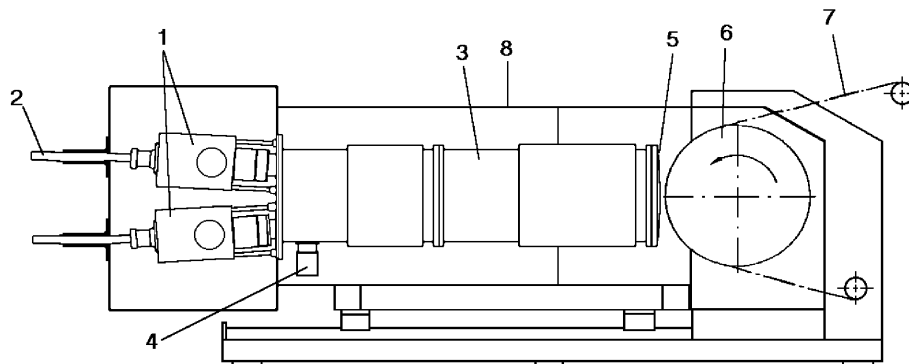

Fig. 11: Electron-beam equipment for roll to roll application (schematically).

Acceleration voltage max. 280 kV, penetration max. 320 g/m² at an ionisation of 80 %.

Dose capacity at 800 m/min = 10 kGy.

Dose accuracy over the working width better ± 3 %.

- 1 Accelerator with two cathodes.
- 2 High-voltage cable.
- 3 Scanning system.
- 4 Pumping system.
- 5 Electron-beam exit window, inertisation zone, disconnection point for maintenance work.
- 6 Drum for material supply.
- 7 Material inlet / outlet.
- 8 Radiation shielding.

The electron accelerator is positioned horizontally and is aimed towards a drum. The drum can be cooled or heated.

Together with a large-surface electron-beam exit window, the drum can be heated up to temperatures of 100°C. The exit window can be operated at temperatures of up to 70°C.

This is an interesting variation of the application technique, particularly with respect to monomer-free materials applied at higher temperatures, and according to the chemicals used, crosslinked in a hot state.

The drum serves to guide the material during the hardening or vulcanisation process and is indispensable for hardening of the lacquer (especially on thin, highly flexible substrates), fig. 11.

Using a drum permits inertisation of the process zone.

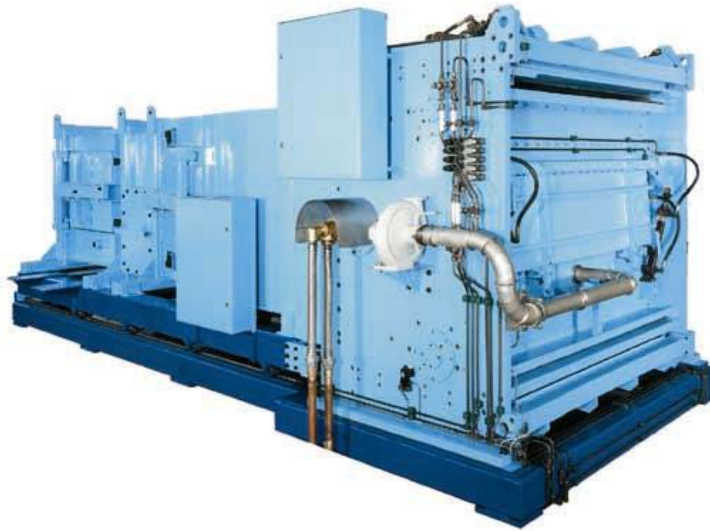

Fig. 13: EB unit for irradiation of material from roll to roll. (280 kV, 400 mA, 1,2 m)

The positioning of the drum described before not only is suitable for crosslinking and vulcanisation of lacquers and pressure-sensitive substances but also is quite advantageous in crosslinking adhesives when manufacturing laminated material for the packaging industry.

4.2.2 Installation for flexible material, roll to roll

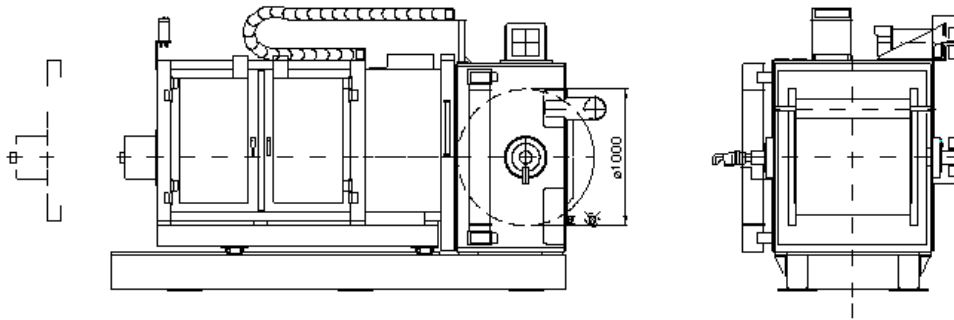

Fig. 14: EB unit for irradiation of material from roll to roll. (schematically).



Fig. 15: EB unit for irradiation of material from roll to roll. (120 kV, 220 mA, 0,6 m)

4.3 Installation for laboratory equipment

There are many different types of laboratory equipment used by the chemical industry for the development of new processes and for quality insurance. Fig. 16. Shows a new type of laboratory equipment that combines a batch and roll to roll equipment suitable for laboratory work.

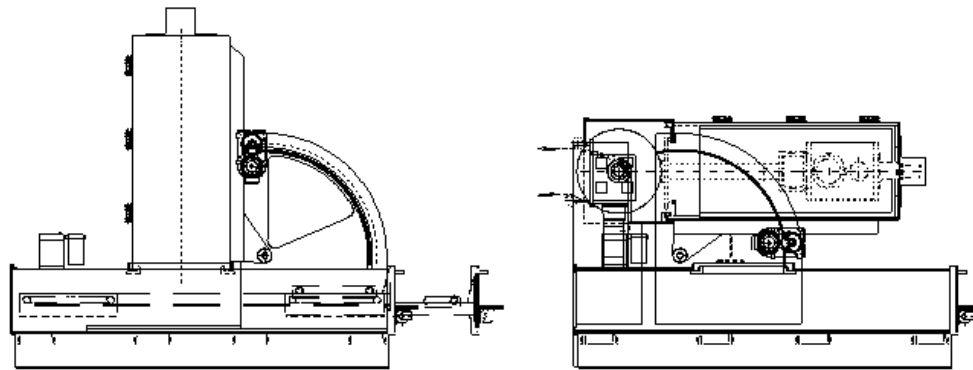

Fig. 16: EB unit for the laboratory system (80 – 300 kV, 400 mm). (schematically).

5. EB -CURING

The advantages of this technique are:

- Environmentally friendly due to a 100 %-solid system. EB generates absolutely no emissions.
- No substrate heating.
- Low energy consumption.
- Substantial production increase compared with conventional heat-treatment methods and UV-technology, also with pigmented layers.
- Immediate further treatment of converted products without post curing.
- Low space requirement. Integration into existing production processes without any problems.
- Exact repeatability of production conditions is obtained due to high dose accuracy. There is also no wastage when starting up and shutting down the plant.

The surface treated with EB-technology is:

- free of harmful substances
- non-ageing
- weather-resistant
- scratch-proof
- colour-stable
- resistant to organic solvents
- resistant to a wide range of chemicals.
- Graffiti resistant

6. SUMMARY

Electron-beam curing and vulcanisation does not only replace physical drying or thermal curing with 100 % systems; new products with improved characteristics can be produced in new ways.

In order to carry on this technology to success, good cooperation between customer, chemistry and plant manufactures is necessary.

7. Literature

- [1] Fa. Svedex, Türenfabrik, NL-7050 Varssefeld
- [2] Fa. Theuma N.V.S.A., Türenfabrik, B-3260 Bekkevoort-Assent
- [3] Profileleisten-Lackierung mit Rundum-Elektronenstrahltröcknung, HK-International 5/92
- [4] A. Lindbladh, From Idea to Industrial Plant with EB-technique, RadTech Europé '93 Mediterraneo, Conference Preceedings
- [5] Fa. Hamberger Industrierwerke GmbH, D-83101 Rosenheim
- [6] Fa. Scannery Holztechnik GmbH, D-16928
- [7] T. Alpar, Elektronenstrahlhärtung bei der Oberflächenveredelung von Zementspanplatten, 13. Münchner Klebstoff-und Veredelungs-Seminar, 1988
- [8] C. Chaix, N.Handegard, Electron beam coatings on polyester panels, Composites-NO 14-mars-Avril 1996
- [9] U. Tenorth, Planung und Realisierung einer modernen ESH-Anlage zur Beschichtung von Holz-Zement-Platten und Holz-Spanplatten, beta-gamma 1/90
- [10] Dekorative Platten mit verbesserten Oberflächeneigenschaften, Hoechst AG, Europäische Patentschrift 0 166 153
- [11] Fa. Glunz GmbH, D-49716 Meppen, Interzum Köln 1993
- [12] Lack-Design-Verfahren für Holzwerkstoffplatten, HK-International 1/94
- [13] Fa. Astrid, I-33033 Codroipo (UD), Interzum Köln 1993
- [14] P. Holl, Elektronenstrahler zur Vernetzung und Vulkanisation von Hot Melts, 16. Münchner Klebstoff-und Veredelungs-Seminar, 1991
- [15] H.D. Diesel, H. Giegold, Folienveredelung mit Hilfe der ESH-Technik, 7. Münchner Klebstoff- und Veredelungs-Seminar, 1982
- [16] H. Haller, 15 years of EB-Technology with WKP, RadTech Europé '93 Mediterraneo Conference Preceedings
- [17] Fa. Taubert GmbH, D-46047 Oberhausen, Patentanmeldung P 42 19 446.6, Verfahren zum Auftragen einer dekorativen Schicht auf ein Trägermaterial.
- [18] Fa. Tetra Pak, S-22186 Lund
- [19] EB lights the way to better film printing, Packaging Digest, April 1991
- [20] P. Klenert, K-H. Krauß, H. Langguth, S. Rummel und R. Mehnert, Strahlhärtung von Druckfarben und analytische Charakterisierung, IOM – Institut für Oberflächenmodifizierung, D-04303 Leipzig
- [21] P. Holl, E.Föll, Electron-Beam for Controlled Environmentally Friendly Through-Curing of Lacquers, Foils and Adhesives, RadTech Europé '93, Mediterraneo, Conference Proceedings
- [22] H. Neuhaus-Steinmetz, Penetration Depth of the Radiation Dose and Dose Yield for Low Energy Electron Beam Accelerators, Radtech '93 Mediterraneo, Conference Proceedings
- [23] P.Holl, Some new aspects on applications of EB curing, RadCureLetter 1/96
- [24] J. McBosch, J.D.LeFors, T.Hetzel, Decorative Particle Board Surfaces via the UV/EB Curing Process – 15 Years of Success, beta-gamma 2/88